



BiHiKu

SUPER HIGH POWER BIFACIAL MONO PERC MODULE

420 W ~ 445 W

UP TO 30% MORE POWER FROM THE BACK SIDE

CS3W-420 | 425 | 430 | 435 | 440 | 445MB-AG



FRONT

BACK

MORE POWER



Up to 30% more power from the back side



24 % higher front side power than conventional modules



Low NMOT: $41 \pm 3 \text{ }^\circ\text{C}$
Low temperature coefficient (Pmax): $-0.35 \text{ \% / }^\circ\text{C}$



Better shading tolerance

MORE RELIABLE



Lower internal current, lower hot spot temperature



Minimizes micro-crack impacts



Heavy snow load up to 5400 Pa, wind load up to 3600 Pa *



linear power output warranty*



enhanced product warranty on materials and workmanship*

*According to the applicable Canadian Solar Limited Warranty Statement.

MANAGEMENT SYSTEM CERTIFICATES*

ISO 9001:2015 / Quality management system
ISO 14001:2015 / Standards for environmental management system
OHSAS 18001:2007 / International standards for occupational health & safety

PRODUCT CERTIFICATES*

IEC 61215 / IEC 61730: VDE / CE / MCS / INMETRO
UL 1703: CSA / IEC 61701 ED2: VDE / IEC 62716: VDE / IEC 60068-2-68: SGS
Take-e-way



* As there are different certification requirements in different markets, please contact your local Canadian Solar sales representative for the specific certificates applicable to the products in the region in which the products are to be used.

CANADIAN SOLAR INC. is committed to providing high quality solar products, solar system solutions and services to customers around the world. No. 1 module supplier for quality and performance/price ratio in IHS Module Customer Insight Survey. As a leading PV project developer and manufacturer of solar modules with over 40 GW deployed around the world since 2001.

* For detail information, please refer to Installation Manual.

ENGINEERING DRAWING (mm)

Rear View

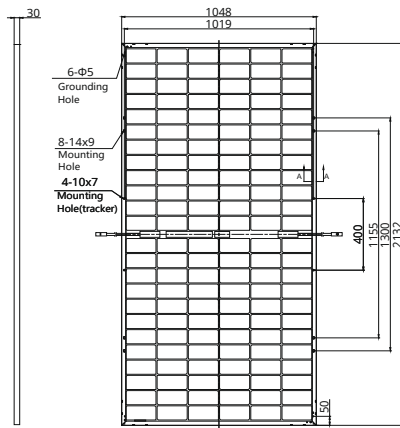

Frame Cross Section

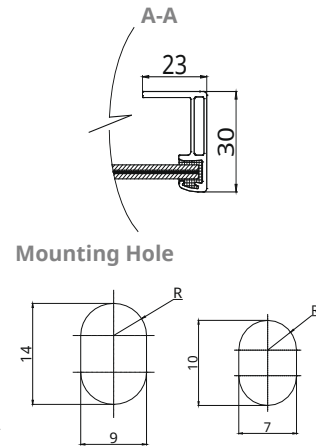

CS3W-435MB-AG / I-V CURVES

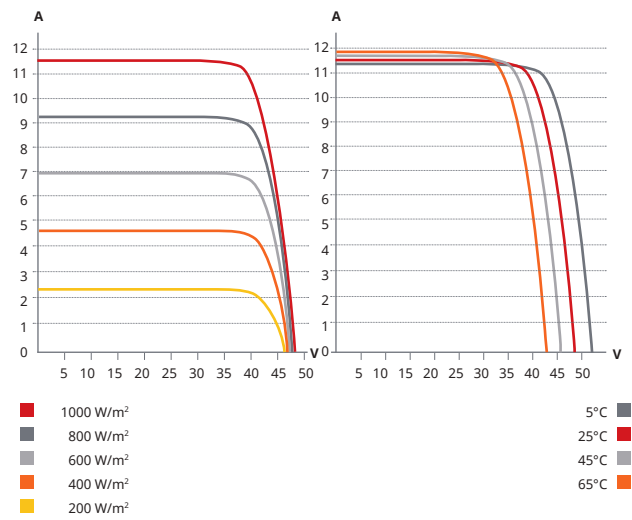

ELECTRICAL DATA | STC*

	Nominal Max. Power (Pmax)	Opt. Operating Voltage (Vmp)	Opt. Operating Current (Imp)	Open Circuit Voltage (Voc)	Short Circuit Current (Isc)	Module Efficiency
CS3W-420MB-AG	420 W	39.9 V	10.53 A	47.9 V	11.27 A	18.8%
Bifacial Gain**	5%	441 W	39.9 V	11.06 A	47.9 V	19.7%
	10%	462 W	39.9 V	11.58 A	47.9 V	20.7%
	20%	504 W	39.9 V	12.64 A	47.9 V	22.6%
	30%	546 W	39.9 V	13.69 A	47.9 V	24.4%
CS3W-425MB-AG	425 W	40.1 V	10.60 A	48.1 V	11.32 A	19.0%
Bifacial Gain**	5%	446 W	40.1 V	11.13 A	48.1 V	20.0%
	10%	468 W	40.1 V	11.66 A	48.1 V	20.9%
	20%	510 W	40.1 V	12.72 A	48.1 V	22.8%
	30%	553 W	40.1 V	13.78 A	48.1 V	24.8%
CS3W-430MB-AG	430 W	40.3 V	10.68 A	48.3 V	11.37 A	19.2%
Bifacial Gain**	5%	452 W	40.3 V	11.21 A	48.3 V	20.2%
	10%	473 W	40.3 V	11.75 A	48.3 V	21.2%
	20%	516 W	40.3 V	12.82 A	48.3 V	23.1%
	30%	559 W	40.3 V	13.88 A	48.3 V	25.0%
CS3W-435MB-AG	435 W	40.5 V	10.75 A	48.5 V	11.42 A	19.5%
Bifacial Gain**	5%	457 W	40.5 V	11.29 A	48.5 V	20.5%
	10%	479 W	40.5 V	11.83 A	48.5 V	21.4%
	20%	522 W	40.5 V	12.90 A	48.5 V	23.4%
	30%	566 W	40.5 V	13.98 A	48.5 V	25.3%
CS3W-440MB-AG	440 W	40.7 V	10.82 A	48.7 V	11.48 A	19.7%
Bifacial Gain**	5%	462 W	40.7 V	11.36 A	48.7 V	20.7%
	10%	484 W	40.7 V	11.90 A	48.7 V	21.7%
	20%	528 W	40.7 V	12.98 A	48.7 V	23.6%
	30%	572 W	40.7 V	14.07 A	48.7 V	25.6%
CS3W-445MB-AG	445 W	40.9 V	10.89 A	48.9 V	11.54 A	19.9%
Bifacial Gain**	5%	467 W	40.9 V	11.43 A	48.9 V	20.9%
	10%	490 W	40.9 V	11.98 A	48.9 V	21.9%
	20%	534 W	40.9 V	13.07 A	48.9 V	23.9%
	30%	579 W	40.9 V	14.16 A	48.9 V	25.9%

* Under Standard Test Conditions (STC) of irradiance of 1000 W/m², spectrum AM 1.5 and cell temperature of 25°C.

** Bifacial Gain: The additional gain from the back side compared to the power of the front side at the standard test condition. It depends on mounting (structure, height, tilt angle etc.) and albedo of the ground.

ELECTRICAL DATA

Operating Temperature	-40°C ~ +85°C
Max. System Voltage	1500 V (IEC/UL) or 1000 V (IEC/UL)
Module Fire Performance	TYPE 3 (UL 1703) or CLASS C (IEC61730)
Max. Series Fuse Rating	25 A
Application Classification	Class A
Power Tolerance	0 ~ + 10 W
Power Bifaciality*	70 %

* Power Bifaciality = $P_{max_{rear}} / P_{max_{front}}$, both $P_{max_{rear}}$ and $P_{max_{front}}$ are tested under STC, Bifaciality Tolerance: ± 5 %

* The specifications and key features contained in this datasheet may deviate slightly from our actual products due to the on-going innovation and product enhancement. Canadian Solar Inc. reserves the right to make necessary adjustment to the information described herein at any time without further notice.

Please be kindly advised that PV modules should be handled and installed by qualified people who have professional skills and please carefully read the safety and installation instructions before using our PV modules.

CANADIAN SOLAR INC.

545 Speedvale Avenue West, Guelph, Ontario N1K 1E6, Canada, www.canadiansolar.com, support@canadiansolar.com

May 2020. All rights reserved, PV Module Product Datasheet V5.59_EN

ELECTRICAL DATA | NMOT*

	Nominal Max. Power (Pmax)	Opt. Operating Voltage (Vmp)	Opt. Operating Current (Imp)	Open Circuit Voltage (Voc)	Short Circuit Current (Isc)
CS3W-420MB-AG	315 W	37.3 V	8.42 A	45.2 V	9.09 A
CS3W-425MB-AG	318 W	37.5 V	8.48 A	45.4 V	9.13 A
CS3W-430MB-AG	322 W	37.7 V	8.54 A	45.6 V	9.17 A
CS3W-435MB-AG	326 W	37.9 V	8.59 A	45.8 V	9.21 A
CS3W-440MB-AG	329 W	38.1 V	8.65 A	46 V	9.26 A
CS3W-445MB-AG	333 W	38.3 V	8.71 A	46.1 V	9.31 A

* Under Nominal Module Operating Temperature (NMOT), irradiance of 800 W/m², spectrum AM 1.5, ambient temperature 20°C, wind speed 1 m/s.

MECHANICAL DATA

Specification	Data
Cell Type	Mono-crystalline
Cell Arrangement	144 [2X (12 X6)]
Dimensions	2132 × 1048 × 30 mm (83.9 × 41.3 × 1.2 in)
Weight	28.4 kg (62.6 lbs)
Front / Back Glass	2.0 mm heat strengthened glass
Frame	Anodized aluminium alloy
J-Box	IP68, 3 diodes
Cable	4.0 mm ² (IEC), 12 AWG (UL)
Cable Length (Including Connector)	Portrait: 400 mm (15.7 in) (+) / 280 mm (11.0 in) (-); landscape: 1400 mm (55.1 in); leap-frog connection: 1850 mm (72.8 in)*
Connector	T4 series or H4 UTX or MC4-EVO2
Per Pallet	33 pieces
Per Container (40' HQ)	660 pieces or 561 pieces (only for US)

* For detailed information, please contact your local Canadian Solar sales and technical representatives.

TEMPERATURE CHARACTERISTICS

Specification	Data
Temperature Coefficient (Pmax)	-0.35 % / °C
Temperature Coefficient (Voc)	-0.27 % / °C
Temperature Coefficient (Isc)	0.05 % / °C
Nominal Module Operating Temperature	41 ± 3°C

PARTNER SECTION

